

## TSB 97-17-16

FORD:

1994-97 THUNDERBIRD

LINCOLN-MERCURY:

1994-97 COUGAR

ISSUE:

A transmission fluid leak may be present at the transmission oil cooler at the radiator. This may be caused by a leaking transmission oil cooler gasket.

ACTION:

Replace the transmission oil cooler gasket to reduce the possibility of fluid leak. Refer to the following Service Procedure for details.

SERVICE PROCEDURE

1. Verify the fluid leak is coming from the connection at the radiator end tank fitting.
2. Drain the cooling system.
3. Remove the radiator as outlined in the appropriate Thunderbird/Cougar Service Manual.
4. Lay the radiator flat on a bench. Be careful not to damage the cooling fins and/or tubes.
5. Remove the oil cooler line fitting (Figure 1).

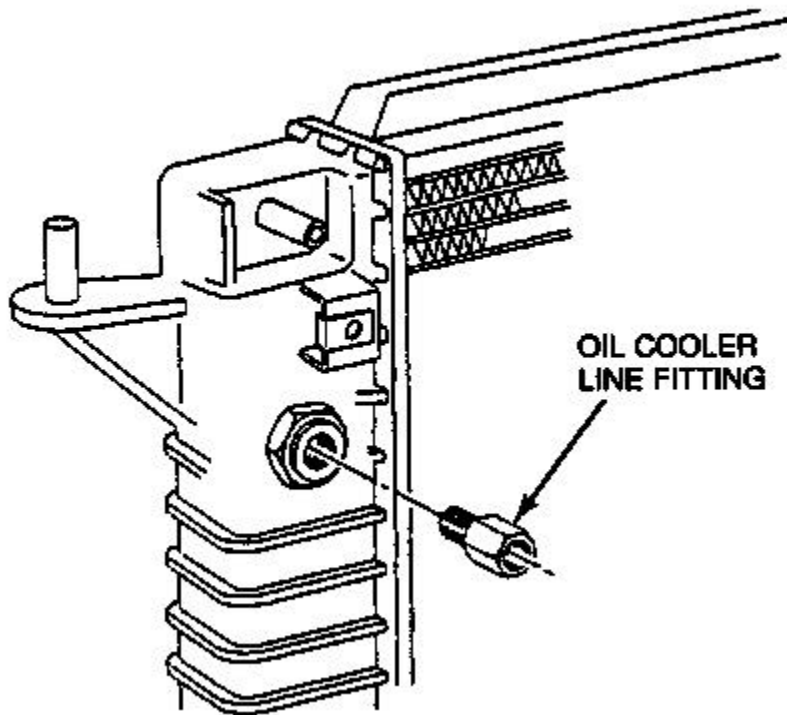

Figure 1 - Article 97-17-16

6. Remove the jam nut and washer (Figure 2).

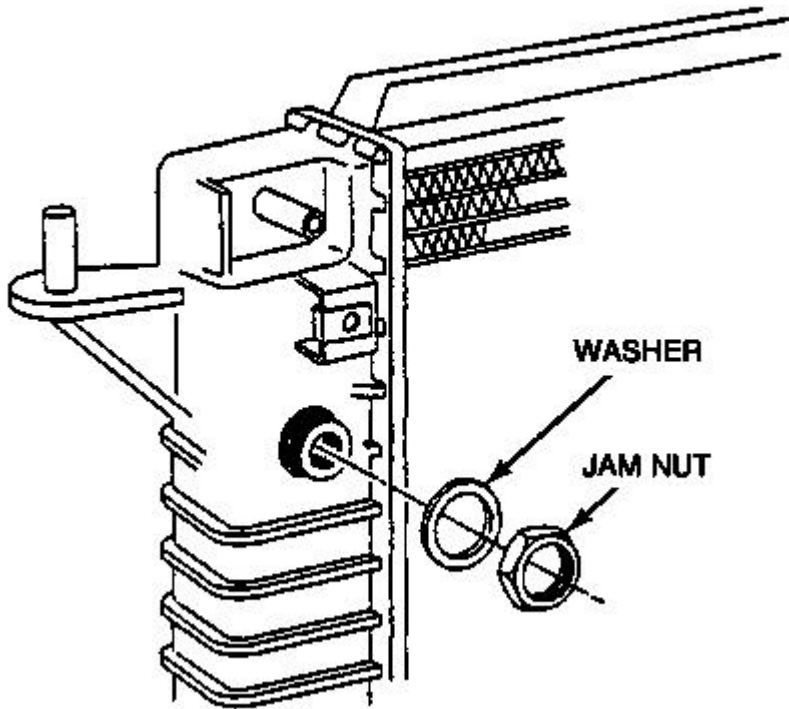

Figure 2 - Article 97-17-16

7. Push down on the transmission oil cooler and slide to the side under the lip of the end tank (Figure 3).

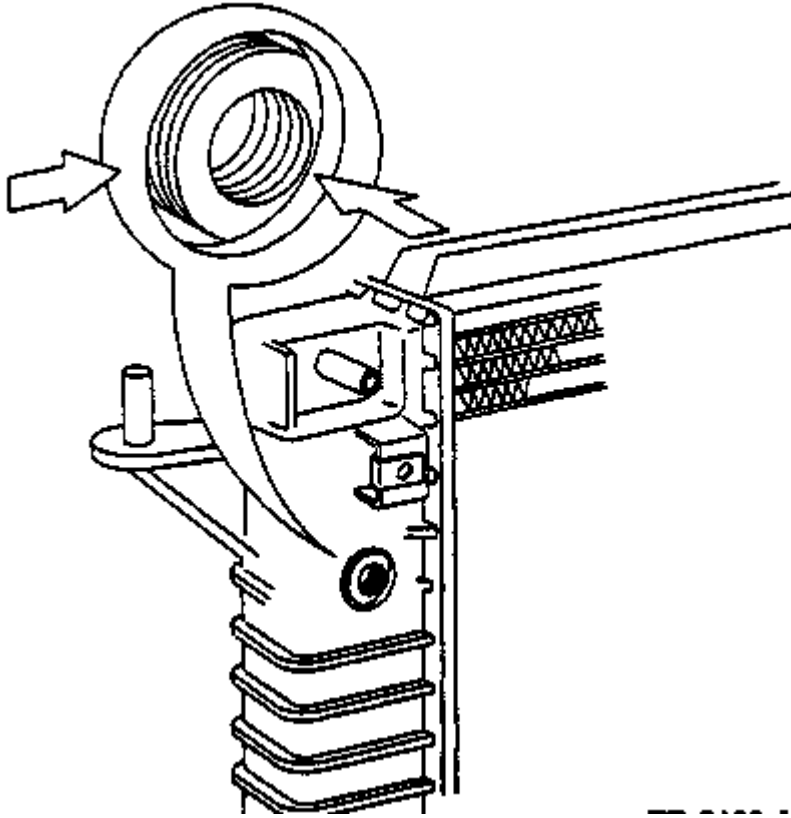

Figure 3 - Article 97-17-16

- 8. Remove the gasket (Figure 4).

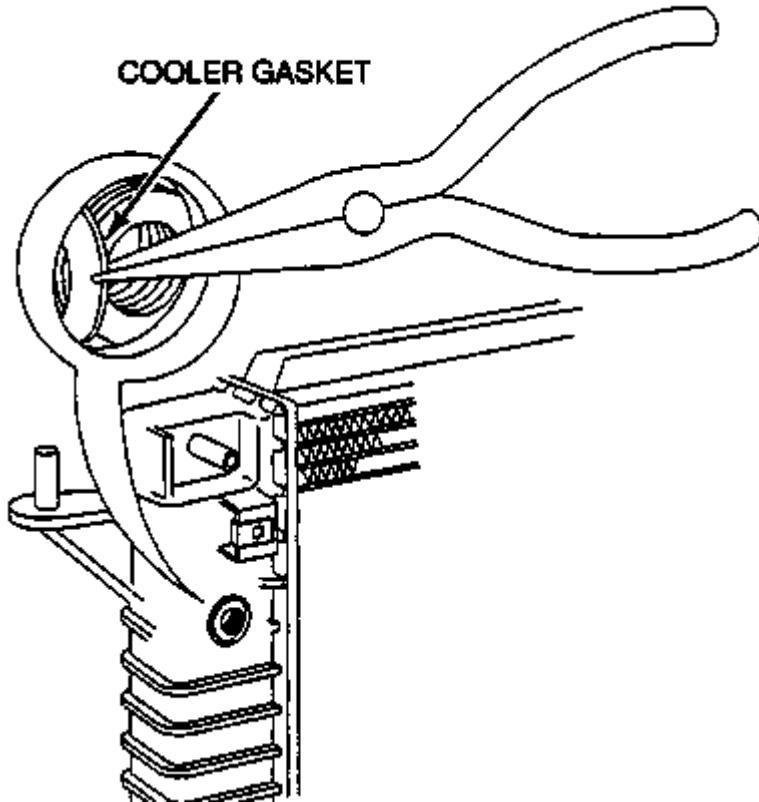

Figure 4 - Article 97-17-16

- 9. Install a new Transmission Oil Cooler Gasket (E77Z-8C242-AA) by placing the gasket over the cooler fitting, pushing down on the oil cooler and carefully working the gasket around the fitting into position.
- 10. Reinstall jam nut and washer, and torque to 15-19 N-m (11-14 lb-ft).
- 11. Install the oil cooler line fitting and torque to 23-33 N-m (17-24 lb-ft).
- 12. Repeat Steps 5-11 for the other cooler fitting if necessary.
- 13. Reinstall the radiator. Refer to the appropriate Thunderbird/Cougar Service Manual.
- 14. Refill the transmission and cooling system.

UAA	
3	3
PART NUMBER	PART NAME
AA	
3 E77Z-8C242-AA	3 Transmission Oil Cooler Gasket
AA	
U	

OTHER APPLICABLE ARTICLES: NONE

WARRANTY STATUS: Eligible Under The Provisions Of Bumper To Bumper Warranty Coverage