



## DESCRIPTION AND OPERATION

### WARNING:

**BRAKE FLUID CONTAINS POLYGLYCOL ETHERS AND POLYGLYCOLS. AVOID CONTACT WITH EYES. WASH HANDS THOROUGHLY AFTER HANDLING. IF BRAKE FLUID CONTACTS EYES, FLUSH EYES WITH RUNNING WATER FOR 15 MINUTES. GET MEDICAL ATTENTION IF IRRITATION PERSISTS. IF TAKEN INTERNALLY, DRINK WATER AND INDUCE VOMITING. GET MEDICAL ATTENTION IMMEDIATELY.**

The hydraulic clutch control system consists of a master cylinder, a concentric slave cylinder, a fluid reservoir and connecting tubing.

Fluid level is checked at the reservoir, mounted on the LH shock tower in the engine compartment. The clutch master cylinder is located outboard of the brake anti-lock unit. It is connected to the clutch pedal by a push rod. The clutch master cylinder converts mechanical pedal movement into hydraulic fluid movement.

The concentric slave cylinder is mounted inside the clutch housing on the transmission, over the input shaft. The slave cylinder converts hydraulic movement back to mechanical movement to operate the clutch release bearing.

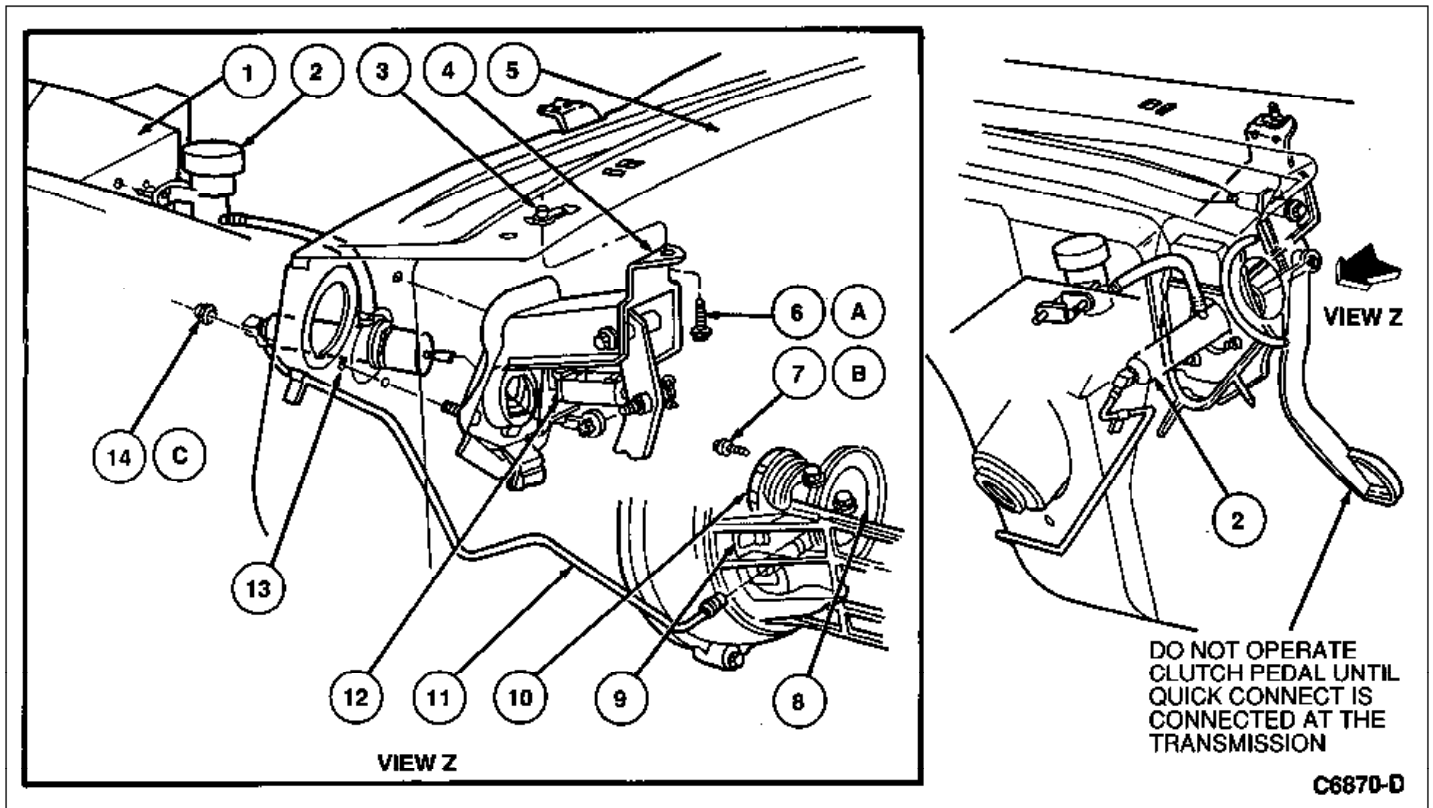

Item	Part Number	Description
1	-	LH Shock Tower
2	7C522	Reservoir

3	N800296-S2	J-Nut
4	7B633	Clutch Pedal Bracket Assy
5	-	Cowl
6A	N801921-S309	Bolt
7B	N605905-S2	Bolt (2 Req'd)
8	7A508	Clutch Slave Assy
9	-	Bleeder Screw
10	7A508	Release Bearing Assy
11	7C522	Clutch Hydraulic Line Assy
12	11A152	Clutch/Starter Switch
13	7C522	Clutch Master Cylinder Assy
14C	N805367-S2	Nut
A		Tighten to 21-30 N-m (16-22 Lb-Ft)
B		Tighten to 20-27 N-m (15-19 Lb-Ft)
C		Tighten to 16-30 N-m (12-22 Lb-Ft)

**NOTE:**

As the clutch disc wears, the fluid level in the reservoir will change. The fill line step in the reservoir is the normal level for a new system.

The hydraulic clutch system eliminates pedal free-play and periodic adjustments. It provides for consistent pedal height throughout the service life of the clutch.

**➔ Clutch/Starter Three Function Interlock Switch**

---